

# Insert Range Hood, 36"

Series 9 | Integrated

Stainless Steel



With edge-to-edge extraction, this efficient, stylish range hood is perfectly hidden away in your cabinetry.

- With five fan speeds, select the perfect extraction rate for your cooking
- With dimmable LED strip lighting
- Powerful 1100CFM maximum airflow
- Dishwasher safe filters that are easy to remove and clean

## DIMENSIONS

Height	18 <sup>3</sup> / <sub>16</sub> "
Width	34 <sup>5</sup> / <sub>8</sub> "
Depth	18 <sup>7</sup> / <sub>8</sub> "

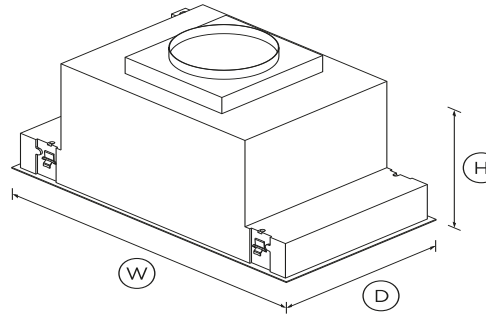

## FEATURES & BENEFITS

### Achieve the invisible

<>

### Edge to edge extraction

Filters effectively reach edge to edge, which maximizes the amount of extraction area.

### Full surface lighting

The even lighting provides full coverage of the cooktop, illuminating food in its true color, with no hot or dark spots and no glare or shadows. The dimmable lights have fade in and fade out features.

### Easy to use

This easy to use range hood operates with fingertip control of LED-illuminated soft touch buttons. Selected models also come with a remote control.

### Energy efficiency

Powered by a brushless DC motor, the Insert Range Hood operates more efficiently, more reliably and with less noise than units with AC motors. Plus, fewer moving parts mean less erosion and longer lifetime.

### Effortless cleaning

The stainless steel filters are easy to remove and are dishwasher safe. A self-contained grease tray within the filters makes them very easy to clean.

### Simple installation

The simple installation process is compatible with most precut cabinetry. The adjustable mounting system can be installed with 5/8" to 9/16" cabinetry board.

## SPECIFICATIONS

### Fan ratings

Maximum air movement	1100CFM
----------------------	---------

### Installation and cleaning

Air outlet size	10"
Dishwasher safe filters	3
Ducted	Vertical only

### Performance

Extraction type	Surface
Fan speeds	5
Filter type	SS Baffle

### Power requirements

Supply voltage **120V**

---

#### Product dimensions

Depth **18 <sup>7</sup>/<sub>8</sub> "**

Height **18 <sup>3</sup>/<sub>16</sub> "**

Width **34 <sup>5</sup>/<sub>8</sub> "**

---

#### Product information

Control type **Electronic**

---

#### Ventilation features

Auto-off/Run-on timer •

Dimmable lights •

Filter cleaning alert •

Light type **3000K LED Strip**

Number of light settings **5**

Over heat sensing •

Remote control •

---

SKU **50110**

---

#### Other product downloads available at fisherpaykel.com



User Guide



Service & Warranty Booklet



Installation Guide



Resources (pdf)



#### A PEACE OF MIND SALE

**24 Hours 7 Days a Week Customer Support**

**T 1.888.936.7872 W www.fisherpaykel.com**

TEST The product dimensions and specifications in this page apply to the specific product and model. Under our policy of continuous improvement, these dimensions and specifications may change at any time. You should therefore check with Fisher & Paykel's Customer Care Centre to ensure this page correctly describes the model currently available. ? Fisher & Paykel Appliances Ltd 2020