

ELYSE Wall Sconces - Outdoor

MODERN FORMS

WS-W58012 / WS-W58017

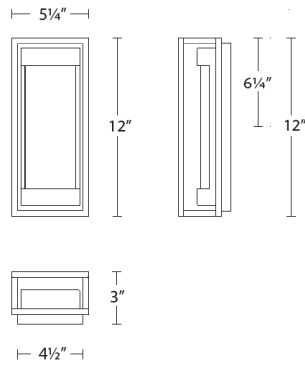

Fixture Type:

Catalog Number:

Project: _____

Location: _____

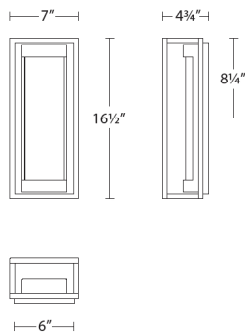

PRODUCT DESCRIPTION

Like with ocean waves in the horizon, light twinkles in the undulating glass within this lantern. The minimalistic frame and discreetly-hidden LED technology for soft illumination are well-suited for entrances of upscale residences and commercial spaces.

FEATURES

- Handcrafted, swirly patterned glass
- Universal Driver (120V-277V) concealed within the fixture
- Mounted vertically or horizontally
- Dimming: ELV, 0-10V, TRIAC
- Rated Life: 50,000 hours
- Color Temp: 3000K
- CRI: 90

SPECIFICATIONS

Construction: Aluminum body with pressed glass

Light Source: High output LED

Finish: Black (BK)

Standards: ETL & cETL, Wet Location listed, IP65 Rated, ADA Compliant

ORDER NUMBER

	Size	Wattage	Voltage	LED Lumens	Delivered Lumens	Finish
WS-W58012	12"	12W	120V-277V	326	192	BK Black
WS-W58017	17"	14W		380	250	

Example: **WS-W58012-BK**

modernforms.com
Phone (800) 526.2588
Fax (800) 526.2585

Headquarters/Eastern Distribution Center
44 Harbor Park Drive
Port Washington, NY 11050

Central Distribution Center
1600 Distribution Ct
Lithia Springs, GA 30122

Western Distribution Center
1750 Archibald Avenue
Ontario, CA 91760